

Series
AG

2,80 faston tags terminal blocks
for PCB mounting

Issue :
Jan 16th, 2017

Page
1/1



NOTES : N → nb of contacts
P → Pitch

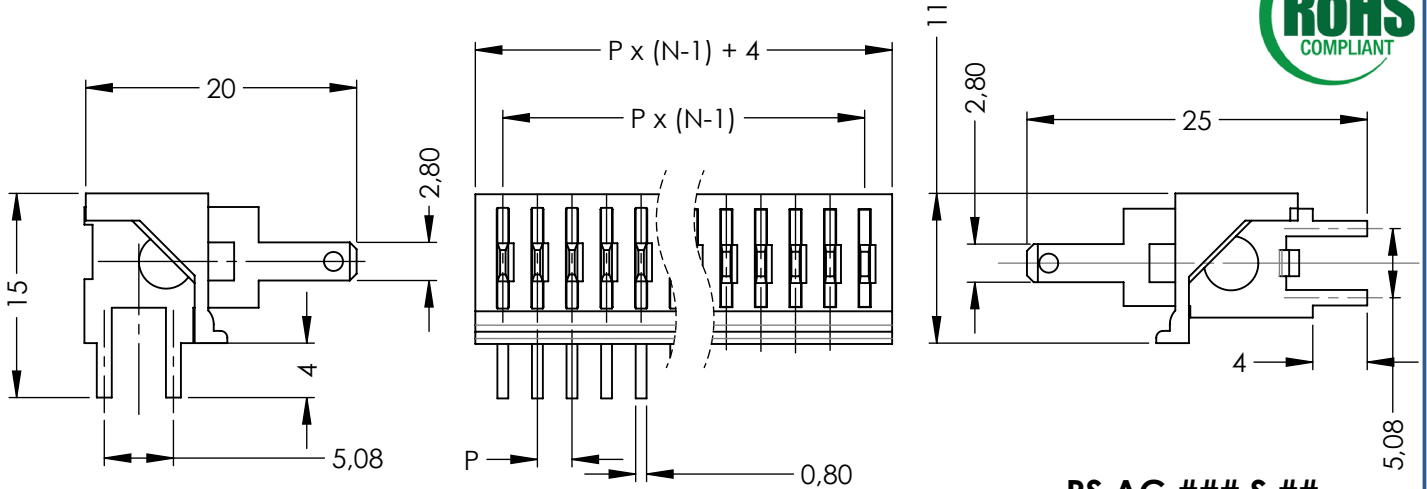

PS AG ### R ##

PS AG ### S ##

PC GRID PATTERN : $\varnothing 1,40$ min.

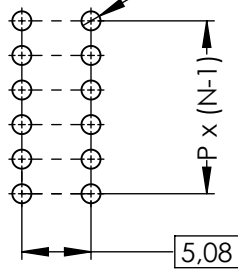

PS AG 254 R 05

PS AG 508 S 13

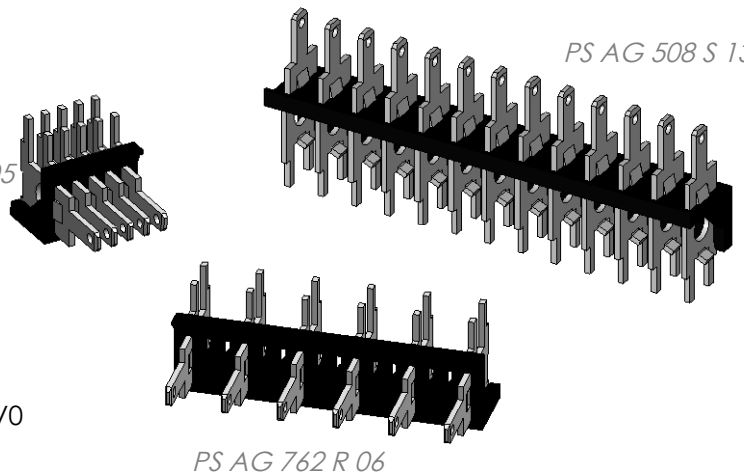

MATERIALS & FINISHES :

- Insulating body : Thermoplastic UL 94 V0
- Contacts : brass, pur tin plated

TECHNICAL CHARACTERISTICS :

- Nominal voltage : 300 V
- Nominal current : 25 A

HOW TO ORDER :

PS AG ### # ##

- 254 → Pitch 2.54
- 508 → Pitch 5.08
- 762 → Pitch 7.62

Number of contact
01 to 25 with 2.54 pitch
01 to 13 with 5.08 pitch
01 to 09 with 7.62 pitch

R → Right angle PC tail contacts
S → Straight PC tail contacts

DIMENSIONS : mm [inch are given for information only]



CREATION				
PROJET :				
NAME : HAY.antoine				
DATE : Jan 16th, 2017				
APPR : CHEVREAU M.				
Issue	Revisions	Name	Approved	

This document is the property of PASMAn, It cannot be reproduced or communicated to a third party without a prior written permission.

www.pasman.fr

This information is given as an indication in the continual goal to improve our products, we reserve the right to make any modifications judged necessary.